



NB-Fi BASE STATION

MODEL NB-300

DATASHEET AND USER GUIDE



Compliance Information

CE Conformity for European Countries

CE Hereby, it's declared that this device is in conformity with the essential requirements and other relevant provisions of the CE.

WEEE Warning



To avoid the potential effects on the environment and human health as a result of the presence of hazardous substances in electrical and electronic equipment, end users of electrical and electronic equipment should understand the meaning of the crossed out wheeled bin symbol. Do not dispose of WEEE as unsorted municipal waste and have to collect such WEEE separately.

Table of Contents

1. Introduction.....	3
2. Technical characteristics of NB-Fi Base Station	4
2.1. Datasheet for the computation unit of NB-Fi Base Station	4
2.2. Datasheet for the antennas for NB-Fi Base Station.....	8
3. Installation	9
3.1. Safety Warnings	9
3.2. Installation Overview	10
3.3. Mounting Diagram	13
3.4. Installation of Antennas	14
3.5. Installation of the Computation unit	14
3.6. Connecting the NB-Fi Base Station to network.....	15
3.7. Logging in to the WAVIoT IoT Platform	15
4. Packing list	16
5. Warranty statement	17
6. Contact Information	18

1. Introduction

WAVIoT is an innovator in low-power wide-area network (LPWAN) technologies that power the M2M telemetry and Internet of Things. WAVIoT uses the NB-Fi standard that is based on Narrow Band radio technology and operates in the license-free Sub-1 GHz frequency bands.

WAVIoT devices connected to the WAVIoT IoT Platform via the NB-Fi protocol use significantly less power and operate over larger distances compared to other wireless technologies which require more power and work best in short range. Numerous devices send data through bi-directional NB-Fi base stations. The base stations then detect, demodulate and transfer received messages to the WAVIoT Head-End System (HES) which is a part of the WAVIoT IoT Platform. WAVIoT Meter Data Management (MDM) system is a WAVIoT IoT Platform application that requests or collects, validates and processes data (e.g. consumption data or events and alarms) and shares it with suppliers, utility management companies and consumers. The HES and MDM systems have API that allows exchanging data with the customer applications such as billing systems, customer care systems and solutions for data analytics.

Plug-and-play IoT devices, NB-Fi modems with pulse, ADC or RS-232/485 inputs and high-performance bi-directional base stations allow deploying NB-Fi networks for IoT applications rapidly (sometimes within hours) in any part of the world. WAVIoT technology and the NB-Fi standard may be applied for Automated Meter Reading (AMR) systems, Advanced Metering Infrastructure (AMI) solutions, wireless alarm and security systems, industrial monitoring and control, smart agriculture and other wireless sensor network solutions.

The WAVIoT team has extensive practical experience in the rollout of large systems with hundreds of NB-Fi devices within a single project, and as a result, all our R&D activities are focused on the challenges that we meet in numerous use scenarios.

This document describes the NB-Fi Base Station and also provides a general overview of WAVIoT technology and the NB-Fi standard for IoT communication.



2. Technical characteristics of NB-Fi Base Station

The NB-Fi Base Station consists of a computation unit and an additional set of antennas and commutation devices.

2.1. Datasheet for the computation unit of NB-Fi Base Station

General characteristics

Dimensions (height×width×depth)	250×120×75 mm
Weight	1.5 kg
Material of the case	Aluminum alloy
Connectors	RG316 N-Type (for RX) RG316 N-Type (for TX) RJ45 with TIA/EIA 568B wiring standard (for power supply and Ethernet)
Max. length of Ethernet cable	80 m
Base station hardware version	H300.EU.01
Base station software version	S300.EU.01

Input voltage data

Supply voltage of the computation unit	6 – 30 V DC
Max. power consumption of the computation unit	10 W
Supply voltage of the PoE Power Supply unit	230 V AC
AC frequency range	45 Hz – 55 Hz
Output voltage of the PoE Power Supply unit	24 V DC

Long Range Communications

Wireless protocol	NB-Fi
Distance ranging	Up to 10 km (urban), up to 30 km (rural)
Network topology	Star

Frequencies supported

RX

(receiving the uplink NB-Fi messages from devices)

Central frequency:	For Europe:	868.1 MHz ¹
	For USA ² :	902 - 928 MHz
	For Australia ³ :	915 - 928 MHz
	For India:	865 - 867 MHz

TX

(sending the downlink NB-Fi messages to devices)

Duty cycle 10%, Adaptive TX Power Control (APC) based on signal strength measurements

Central frequency:	For Europe:	869.6 MHz ⁴
	For USA ² :	902 - 928 MHz
	For Australia ³ :	915 - 928 MHz
	For India:	865 - 867 MHz

Maximum RF TX Power Software adjustable, up to 500 mW

Uplink packets characteristics

Modulation type	DBPSK
Data rate	50, 400, 3 200, 25 600 bit/s
Sensitivity	
for 50 bit/s data rate:	-148 dBm
for 400 bit/s data rate:	-141 dBm
for 3 200 bit/s data rate:	-132 dBm
for 25 600 bit/s data rate:	-123 dBm
Total RX dynamic range	101 dB
Total RX bandwidth	51.2 kHz + 204.8 kHz (optional)

¹ Can be adjusted by request to work at the following frequency ranges: 865.6 – 865.8 MHz, 866.2 – 866.4 MHz, 866.8 – 867.0 MHz, 867.4 – 867.6 MHz, 868.0 – 868.6 MHz

² For USA, Canada, Mexico, Ecuador

³ For Australia, New Zealand, Argentina, Brazil, Chile

⁴ Can be adjusted by request to work at the following frequency ranges: 865.6 – 865.8 MHz, 866.2 – 866.4 MHz, 866.8 – 867.0 MHz, 867.4 – 867.6 MHz, 869.4 – 869.65 MHz

Uplink multiple access	Time & Frequency
Number of simultaneously received channels	
for 50 bit/s data rate:	1 024
for 400 bit/s data rate:	128
for 3 200 bit/s data rate:	16 + 64 (optional)
for 25 600 bit/s data rate:	2 + 8 (optional)
Maximum data transfer per 24 h	20 Mbit + 40 Mbit (optional)

Downlink packets characteristics

Modulation type	DBPSK
Data rate	50, 400, 3 200, 25 600 bit/s
Downlink multiple access	Time
Maximum data transfer per 24 h	10 Mbit ⁵
Duty cycle	10%

Ambient conditions

Ingress protection	IP66
Ambient temperature (operation)	From -50°C to 70°C
Max. permissible relative humidity (operation)	≤ 95% (at 25°C, non-condensing)
MTBF	12 years – <i>non contractual</i>

Certification

Electromagnetic compatibility

Radio Equipment Directive (RED) 2014/53/EU Modifications for EU countries

⁵ When all devices operate at the 25 600 bit/s Downlink data rate



Figure 1 – computation unit with PoE Power Supply unit

We are continuously developing the technology delivering outstanding innovative solutions to our product range, therefore the specifications may change with time.

Warning: Do not open the computation unit of your base station. Opening the case of computation unit will void any remaining warranty. This computation unit is not field-serviceable, please contact WAVIoT Support if you need assistance with your base station or warranty service.

2.2. Datasheet for the antennas for NB-Fi Base Station

Parameter	Antenna	
	RX whip antenna	TX loop dipole antenna
Description		
Dimensions, not more	1560×36×36 mm	515×295×40 mm
Antenna gain	5 dBi	2 dBi
Horizontal beam width	360°	360°
Vertical beam width	10°	90°
Standing wave ratio (SWR)	<1.5	
Connector	RG316 N type	
Coaxial cable	RG316 50 OHm	
Length of coaxial cable	1 m	



Figure 2.1 –
RX whip antenna



Figure 2.2 –
TX loop dipole antenna

3. Installation

3.1. Safety Warnings

Please read and understand all safety warnings before commencing the installation. Failure to follow operating instructions can result in death or serious injury.

Only trained and qualified personnel shall perform installation, adjustments and servicing of the mast and base station. Only a properly trained and qualified certified electrician shall perform electrical installation and service.

Electrical Power Warning

Do not locate any antenna near overhead power lines or other electric light or power circuits, or where the antenna can come into contact with such circuits. When installing antennas, take extreme care to prevent contact with such electrical circuits, as it can cause serious injury or death.

A safe grounding system is necessary to protect your NB-Fi Base Station from lightning strikes and the build-up of static electricity when installed in an outside environment. Direct grounding of the antenna mast and NB-Fi Base Station is important. When mounting the base station to an antenna mast, you have to connect the base station to the same grounding system that the AC wall outlet has.

The grounding system must comply with the National Electrical Code and safety standards that apply in your country. Always check with a qualified electrician if you are in doubt as to whether your outdoor installation is properly grounded.

Lightning Activity Warning

Do not work on the system or connect or disconnect cables during periods of lightning activity. The NB-Fi Base Station is designed to be installed in an outdoor environment, typically on a tower or a tall building. Plan your installation carefully and completely before you begin. Do not work on a wet or windy day. Do dress properly, use shoes with rubber soles and heels, long sleeved shirts or jackets to avoid the risk of coming in contact with live mains wiring.

Mounting Structure Warning

Before operation, check that the mounting structure is capable of resisting forces generated from all loading and environmental conditions, including, but not limited to, mast size and weight, payload size and weight, wind speed, guy line arrangement, support bracket or roof line location and base plate assembly.

Tip Over and Crush Warning

Mast tip over can result in death or serious injury. Do not operate in high winds. Operate on level ground only. Stand clear of the mast and mast payload during operation. Check that the mast is levelled and secured before and during installation, operation and maintenance. Sudden failure of the mast can result in death or serious injury. Do not stand directly beneath the mast or its payload. Check that the payload is properly installed and secured.

Entanglement Warning

Tangled cables can cause equipment damage. Ensure cables are not tangled and are free to pay out as the mast is raised.

3.2. Installation Overview

NB-Fi Base Station is a radio device capable of transmitting in unlicensed frequency bands. Because the NB-Fi Base Station operates in the unlicensed radio frequency bands, it is susceptible to interference that can reduce throughput and range. Follow these simple guidelines to optimize product performance:

- Install the NB-Fi Base Station and antennas in an area where structures, trees, or hills do not obstruct radio signals to and from the unit
- Install the NB-Fi Base Station and antennas at a height sufficient to provide a clear line-of-sight signal path

Choosing the best place for installing the base station

The best place for the NB-Fi Base Station installation is a roof of the tallest building available in the area. Antenna should be installed on a mast as high as practically possible. The computation unit can be mounted on the mast or, with an additional wall-mounting bracket, to the side of a building.

Main criteria for choosing the place for antenna installation:

- Place of installation: on top of the tallest building in the area
- Antenna shall be mounted on a mast with a height of not less than 3 meters
- Antenna shall be mounted at least 3 meters higher than other objects in the surrounding area such as walls, cornices, parapets, rails, other equipment or antennas



Figure 3.1 –
Correct antenna installation position

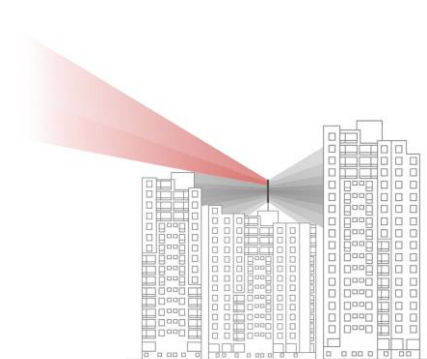
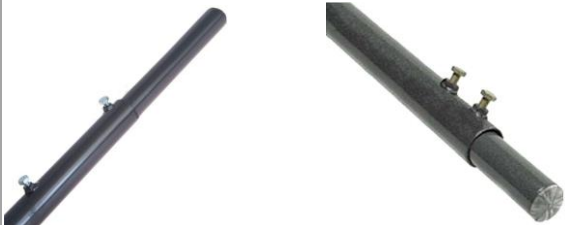

Figure 3.2 –
Incorrect antenna installation position

Tools and Materials Required for Installation

Table 1 provides a list of recommended tools and materials required to install the WAVIoT base station.

Tools and Materials	Comments
Steel telescopic antenna mast <ul style="list-style-type: none"> • 3-4 m length • 2 or 3 sections • The maximum mast top outside diameter: not more than 30mm 	 <p style="text-align: center;">Sample of a mast</p>
Mount accessories for the mast <ul style="list-style-type: none"> • Mast ground base plate • Wall mount brackets • Guy wire support 	Depends on the particular place of installation
Tools and materials to mount the mast <ul style="list-style-type: none"> • Hammer drill • Drills for the hammer drill (choose according to the diameter of the anchors for the brackets, be sure to have M6 size) • 50m extension power cord reel • Hammer • Level 	
Solid copper grounding wire 2.5mm ² , 10m	For grounding of the antenna mast
Wrenches for 13 mm, 10 mm, 8 mm, 6 mm nuts	For nuts in the mounting kit
Plastic box with two cable glands, size not less than 200x200 mm with mount accessories: <ul style="list-style-type: none"> • Self-tapping 6x50 mm screws and dowels, pcs, for wall mounting • Copper cable 3x1.5 mm, up to 30 meters or 3-plug 230V surge protected extension cord (for power supply) • Power plug 230V with grounding • 3-plug power socket 230V with grounding Alternative: 3-plug 230V surge protected extension cord	For placing of PoE adapter and router with LTE modem inside the box. Plastic box must only be placed indoors in dry place! For plug the PoE adapter and router. PoE adapter and router must only be placed indoors in dry place!
Screwdrivers	
USB LTE modem with SIM card	Optional. Either USB LTE modem with SIM card or Internet connection (with enabled DHCP) needed to connect the base station to the Internet.

Tools and Materials	Comments
100+m UTP cat.5 Network cable reel	It is recommended to leave a spare length of cable when mounting the base station. Corrugated pipes may be required for wiring through the walls/floors.
RJ45 connectors	At least 6 pcs
Wire-cutters	
Crimper for RJ45 cable	
RJ45 Lan Tester	For testing cable between base station and PoE
Multimeter	To verify power is turned OFF
Cable ties	
Insulating tape	
Black marker	
Personal protective equipment <ul style="list-style-type: none"> • Protective gloves • Face mask with eye shield 	For each worker

Table 1. Tools and Materials Required for Installation

Some additional tools and materials may be required depends on the place of installation at the discretion of workers.

3.3. Mounting Diagram

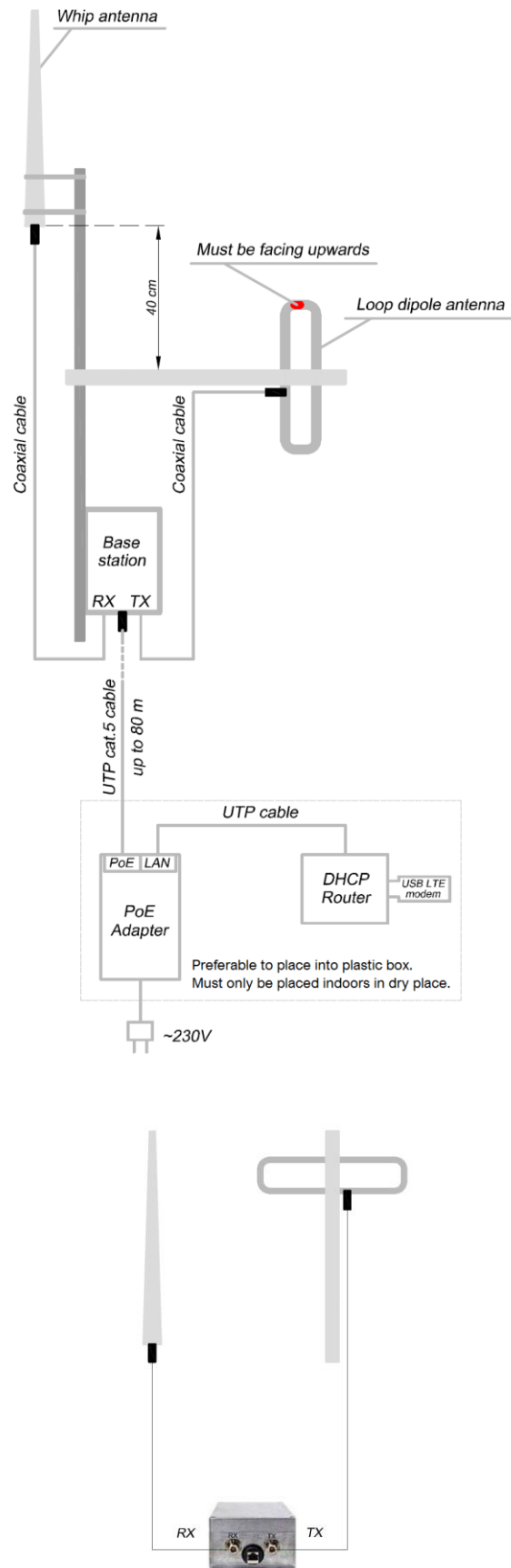

Figure 4 – Mounting Diagram

3.4. Installation of Antennas

Install the antennas first:

- The RX Whip antenna must be mounted to the mast strictly vertically. The deviation from the vertical position must not exceed 0.5°
- The TX Loop dipole antenna must be mounted to the mast at an angle of 90°. The orientation label on the Loop dipole antenna must face upwards

Use a nut wrench to tighten the U-bolts and secure the antennas enclosure in place. When tightening the U-bolts, ensure that the bolts are not twisted. The ends of each U-bolt should be protruding from the bracket evenly at the same distance.

Antennas (or mast) must be grounded properly by copper wire, with a cross-section area of at least 2.5 mm², connected to the grounding system. The grounding system must be same that the AC wall outlet has. It is not recommended to use the grounding system of the building's lightning protection.

The antennas are connected to the computation unit by coaxial cables. It is recommended that the connection points of the threaded connectors pass through the heat-shrinkable tubing or wrapped with insulating tape after installation.

Coaxial cables should be tightened to the mast by cable ties. Cable ties must not be degrading cable integrity and geometry, though it should be fixed tightly.

3.5. Installation of the Computation unit

Computation unit should be mounted to the vertical mast in upright position. To mount the Computation unit onto a vertical mast, attach the U-bolts to the brackets. Adjust the Computation unit enclosure to the desired position on the mast (move up or down). It's recommended to leave a spare length of Ethernet cable when mounting the base station.

Use a nut wrench to tighten the U-bolts and secure the Computation unit enclosure in place. When tightening the U-bolts, ensure that the bolts are not twisted. The ends of each U-bolt should be protruding from the bracket evenly at the same distance.

Ethernet cable should be tightened to the mast by cable ties. Cable ties must not be degrading cable integrity and geometry, though it should be fixed tightly. It's recommended to use a protective corrugated pipe for the Ethernet cable.

Computation unit (or mast) must be grounded properly by copper wire, with a cross-section area of at least 2.5 mm², connected to the grounding system. The grounding system must be the same that the AC wall outlet has. It is not recommended to use the grounding system of the building's lightning protection.

**IMPORTANT: DO NOT TURN ON THE BASE STATION
WITHOUT CONNECTED TX ANTENNA!**

Damage to the transmitter will occur, which is not covered by any Factory Warranty.

3.6. Connecting the NB-Fi Base Station to network

Before connecting the Ethernet cables, it is necessary to put the cables through the covers with seals of cable glands.

Wire sequence of RJ45 plug should conform with EIA/TIA568B standard.

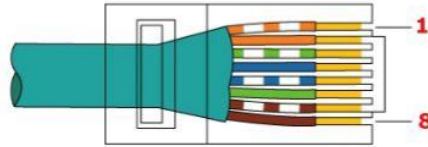

Figure 5 – EIA/TIA568B Ethernet Plug Wiring

Use the following steps to connect the base station to network:

- Connect an Ethernet cable to the Ethernet port on the base station, then connect the other end of the Ethernet cable to the output port on the Power-over-Ethernet (PoE) Power Supply unit
- Connect an Ethernet cable to the input port on the PoE Power Supply unit, then connect the other end of the Ethernet cable to a router with enabled DHCP
- Connect the power cable to the back of PoE Power Supply unit and power the unit on

Do not turn on the base station without connected TX antenna – damage to the transmitter will occur, which is not covered by any factory warranty.

3.7. Logging in to the WAVIoT IoT Platform

After connecting to the Internet, the NB-Fi Base Station will send the data to the WAVIoT Head-End system (HES). Default address for the WAVIoT HES is <https://hes.waviot.com>.

To get your access credentials fill in the registration form at <https://auth.waviot.com> or get them from your supplier of the WAVIoT equipment.

You can check the software and hardware version of the base station at WAVIoT HES.

4. Packing list

The following components are included in your package:

#	Item	Quantity	Comment
1	Computation unit with mounting kit	1	Required
2	Packing list	<input type="text" value="1"/>	Required
3	PoE Power Supply unit 24 V DC	<input type="text"/>	Optional
4	RX Whip antenna with mounting kit	<input type="text" value="1"/>	Required
5	TX Loop dipole antenna with mounting kit	<input type="text" value="1"/>	Optional
6	Coaxial cable	<input type="text" value="1 or 2"/>	According to the number of antennas
7	Wi-Fi router	<input type="text"/>	Optional
8	LTE Modem	<input type="text"/>	Optional

Latest datasheet and user guide can be downloaded from www.waviot.com.

Check this packing list before installation to ensure that you have received all items. If you are missing any items, contact your supplier.

The packaging information section is filled by the manufacturer:

Packaging information

NB-Fi Base Station model NB-300

Serial # _____ Security seal # _____
(factory number) (security seal number)

Packed by Telematics Solutions LLC.

Employee: _____ QA engineer _____
(signature) (position) (full name)

Date of packing: _____
(day, month, year)

5. Warranty statement

WAVIoT warrants to the original end user (purchaser) that the NB-Fi Base Station is free from any defects in materials or workmanship under normal use for a period of two (2) years from the date of purchase. During the warranty period, and upon proof of purchase, if the product fails due to faulty workmanship and/or materials, WAVIoT will, at its sole discretion, repair or replace the defective product or components. However, when repair or replacement is not practical, WAVIoT may, at its sole discretion elect to refund the original purchase price of the defective product. Any replacement may consist of a new or re-manufactured functionally equivalent product of equal value, and will be made solely at the discretion of WAVIoT. Repaired or replaced hardware is warranted only for the remainder of the original warranty period or 60 days from the date of replacement, whichever is longer, and is subject to the same exclusions and limitations as the original product. Unless expressly stated otherwise within this document, the purchaser is responsible for all shipping, labor, installation, and other costs associated with the repair and/or replacement. All hardware or part thereof that is replaced by WAVIoT, or for which the purchase price is refunded, shall become the property of WAVIoT upon replacement or refund.

The following are excluded from the warranty:

- Product defects that result from improper operating, mounting, maintenance, or use of the device
- Unauthorized modifications made by parties other than the manufacturer, or if the original security seal have been defaced, altered, or removed
- Damages during transportation or storage
- Catastrophes caused by external influences and force majeure, including lightning strike
- Vandalism from people or animals
- Exposure to environmental conditions outside of the device's rated specifications

6. Contact Information

Technical support

Once the NB-Fi Base Station and antennas are properly installed, you may contact our technical support for any assistance. Please use the following contact details for technical support and troubleshooting: support@waviot.com.

All rights reserved. NB-Fi and WAVIoT are trademarks of WAVIoT Integrated Systems, LLC or its subsidiaries in the United States and/or other countries. WAVIoT Integrated Systems, LLC owns the rights to a number of patents, trademarks, copyrights, trade secrets, and other intellectual property.

Reproduction in whole or in part is prohibited without the prior written consent of the copyright owner. The information presented in this document does not form part of any quotation or contract, is believed to be accurate and reliable and may be changed without notice. No liability will be accepted by the publisher for any consequence of its use. Publication thereof does not convey nor imply any license under patent or other industrial or intellectual property rights.

WAVIoT Integrated Systems, LLC or its officers, employees, subsidiaries, affiliates, and distributors assumes no responsibility or liability whatsoever for any failure or unexpected operation resulting from misuse, neglect improper installation, repair or improper handling or unusual physical or electrical stress including, but not limited to, exposure to parameters beyond the specified maximum ratings or operation outside the specified range.

WAVIoT products are not designed, intended, authorized or warranted to be suitable for use as a critical component in life-support applications, devices or systems or other critical applications. Inclusion of WAVIoT products in such applications is understood to be undertaken solely at the customer's own risk. Should a customer purchase or use WAVIoT products for any such unauthorized application, the customer shall indemnify and hold WAVIoT Integrated Systems, LLC and its officers, employees, subsidiaries, affiliates, and distributors harmless against all claims, costs damages and attorney fees which could arise.